

SONIC SENTINEL[®]

MODEL 14-1



USER'S MANUAL

SONIC SENTINEL, LLC

www.sonicsentinel.com

440 W White Pine Dr

Murray, UT 84123

(877)-618-9830

Table of Contents

1. Introduction	pg. 2
2. Safety Precautions	pg. 2
3. Product Specifications	pg. 3
4. Initial Setup	pg. 4–5
5. Operation	pg. 6–7
6. Troubleshooting	pg. 8
7. Legal	pg. 9
8. Parts View & Listing	pg. 10–11
9. Warranty	pg. 12
10. Compliance	pg. 12

1. Introduction

Thank you for purchasing the Sonic Sentinel Model 14-1 Sound Cannon. It is designed to humanely discourage wildlife from occupying undesirable or unsafe locations. Preventing such habitation can help avoid property damage, fines, injury to wildlife, and loss of human life.

2. Safety Precautions

Safe operation of the Sonic Sentinel Model 14-1 Sound Cannon is the operator's sole responsibility and requires strict observation of the safety precautions outlined below. Failure to do so will void the manufacturer's warranty and could result in property damage, serious injury, or death.



1. **Explosive Propane Gas** - For outdoor use only. No smoking or open flame within 50 feet. Never point cannon toward people, obstruct the barrel, or attempt to fire projectiles. Do not alter the LPG regulator or tank connector in any way. Use only with OPD equipped tanks of not more than 40lbs.



2. **Extreme Sound** - Hearing protection must be worn within 50 feet of cannon while in operation.



3. **High Voltage** - Do not touch any components under the black plastic electronics cowling when the power switch is in the on position or without first disconnecting the battery terminals.



4. **Lead Acid Battery** - Do not puncture, short, or reverse polarity. Replace only with battery of same type and rating. Dispose of in accordance with local laws and regulations.

3. Product Specifications

Model 14-1 (M14-1) Specifications	
Sound Pressure Level:	130dB @ 1m
Selectable Firing Frequency:	30sec – 2hr with 2 Random Modes and Multi-Shot (1, 2, or 3)
Chronometer Precision:	+/- 1%
Operating Temperature Range:	-5°F – 140°F (-20°C – 70°C)
LPG Efficiency: (LPG Tank Not Included)	> 20,000 Cycles (20lb tank)
Electrical Draw:	< 0.2mA Standby 0.0004Ah Per Cycle
Battery Capacity: (Battery Included)	8Ah SLA 12VDC
Dimensions (w/o Tripod)	40in (101.6cm) L 10in (25.4cm) W 5in (12.7cm) H
Weight (w/o LPG Tank)	Cannon: 22.5lb (10.2kg) Tripod: 8.0lb (3.6kg) Shipping: 37.0lb (16.8kg)
Emissions Compliance:	FCC: Part 15, Subpart B EN: 61000-6-3:2007 ICES: 001, Issue 4

4. Initial Setup

1. Remove the M14-1 cannon and tripod from their packaging. Retain packing material for future transportation needs.
2. Install M14-1 cannon onto tripod:
 - a. Remove bolts and springs from barrel clamp at top of tripod (Fig. 1).

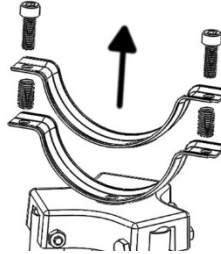

Figure 1

- b. Rotate top half of clamp 180 degrees and *loosely* re-install springs and bolts (Fig. 2).

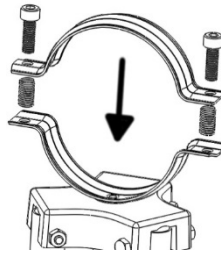

Figure 2

- c. Slide barrel of M14-1 cannon into barrel clamp and align over **CLAMP** decal (Fig. 3).

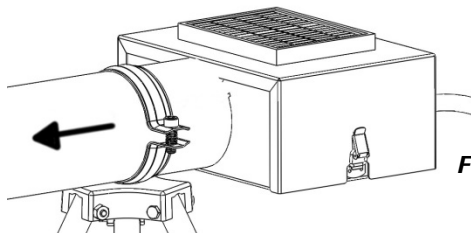

Figure 3

- d. Tighten barrel clamp bolts with the provided 6mm wrench.

3. Connect battery:
 - a. Ensure the M14-1 cannon's power switch is in the off (down) position.
 - b. Remove top shroud and foam battery insulator. Do *not* discard the foam insulator!
 - c. Remove and discard the two, small, plastic battery terminal insulators.
 - d. Connect the negative (-) black wire to the battery's negative (-) black terminal.
 - e. Connect positive (+) red wire to the battery's positive (+) red terminal.
 - f. Replace foam battery insulator.

4. Set delay timer to desired firing interval (Fig. 4):

- a. **OFF:** Delay timer is disabled, but cannon can be triggered remotely via activation modules.

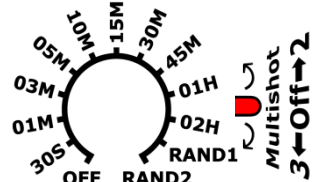

- b. **RANDOM:** Cannon will fire randomly every 1–10min (**RAND1**) or every 5–30min (**RAND2**).

c. **Note:** Frequencies less than 5min should *not* be used in conjunction with our activation modules.

5. Set multi-shot switch (right of delay timer, Fig. 5) to desired shot count: center=1, up=2, or down=3.
6. Reinstall top shroud. Ensure that the solar panel wires remain connected and fold into the space between the battery and barrel.
7. Connect propane tank (not included):
 - a. Suspend a standard, user provided, 20lb propane tank from the M14-1 tripod's 3 S-hooks with valve opening facing aft.

Note: 30-40lb tanks can be used in conjunction only with Sonic Sentinel's tripod extension kit.

- b. Securely fasten the M14-1 regulator's OPD connector to the propane tank valve.

5. Operation

1. Select a suitable outdoor location for the M14-1 cannon that meets the following criteria:
 - a. On level, solid ground to prevent tipping

Note: Optional tripod feet are available to support the M14-1 cannon on unstable surfaces.

- b. Free of debris and combustible material
 - c. In direct sunlight and free from overhead obstructions shading the solar panel

Note: For sustained operation, the solar panel of the M14-1 cannon should receive at least 5 hours of direct sunlight each day.

- d. Clearly visible to passers-by
 - e. Facing downwind relative to prevailing winds
 - f. Away from residential or other sound sensitive areas

Note: The M14-1 cannon is capable of producing sound levels that may violate local noise ordinances. Ensuring legal operation of the M14-1 is the operator's sole responsibility and should only be conducted only in accordance with local laws and regulations.

- g. As close to the desired deterrent zone as possible taking the above factors into consideration.
2. Ensure that all of the following conditions are met before proceeding:
 - a. Barrel of M14-1 is not obstructed and is pointed away from people and objects
 - b. Propane tank connection is secure
 - c. No sources of ignition are present
 - d. Any persons within 50 feet of cannon are wearing ear protection.

3. Open propane tank valve and turn power switch on (up).

Note: There is a 30 second power-up delay, during which the M14-1 cannon will not activate, to provide adequate time to safely clear the immediate area.

Note: Battery voltage must be *above* 12 volts in order for the M14-1 cannon to initialize.

4. Following the power-up delay, the M14-1 cannon will begin firing at the delay timer interval configured during initial setup.

Note: There is a 30 second post-fire delay, during which the M14-1 cannon will not activate, to prevent wasteful and potentially hazardous continuous firing.

5. When in the “**OFF**” position, the delay timer is disabled, but the cannon can still be triggered remotely via activation modules.

Note: When the M14-1 cannon is used in conjunction with any of Sonic Sentinel’s activation modules, the delay timer’s current countdown is reset and begins anew after each commanded detonation.

6. Change the location and detonation frequency of the M14-1 cannon frequently to prevent wildlife from habituating to its effect.

Caution: *Always* power down the M14-1 cannon and close the propane tank valve *before* removing the top shroud to update the delay timer!

7. Periodically clean the solar panel using a damp cloth.

Note: Regularly remove any snow accumulation or other debris from the solar panel to ensure the battery stays charged.

8. Close propane tank valve and turn power switch off (down) when not in use to prevent accidental firing.

Note: When storing the M14-1 cannon for long periods (> 1 week), disconnect the battery to prevent discharge.

6. Troubleshooting

The following flowchart outlines several common problems and their solutions. For other questions, please contact support@sonicsentinel.com.

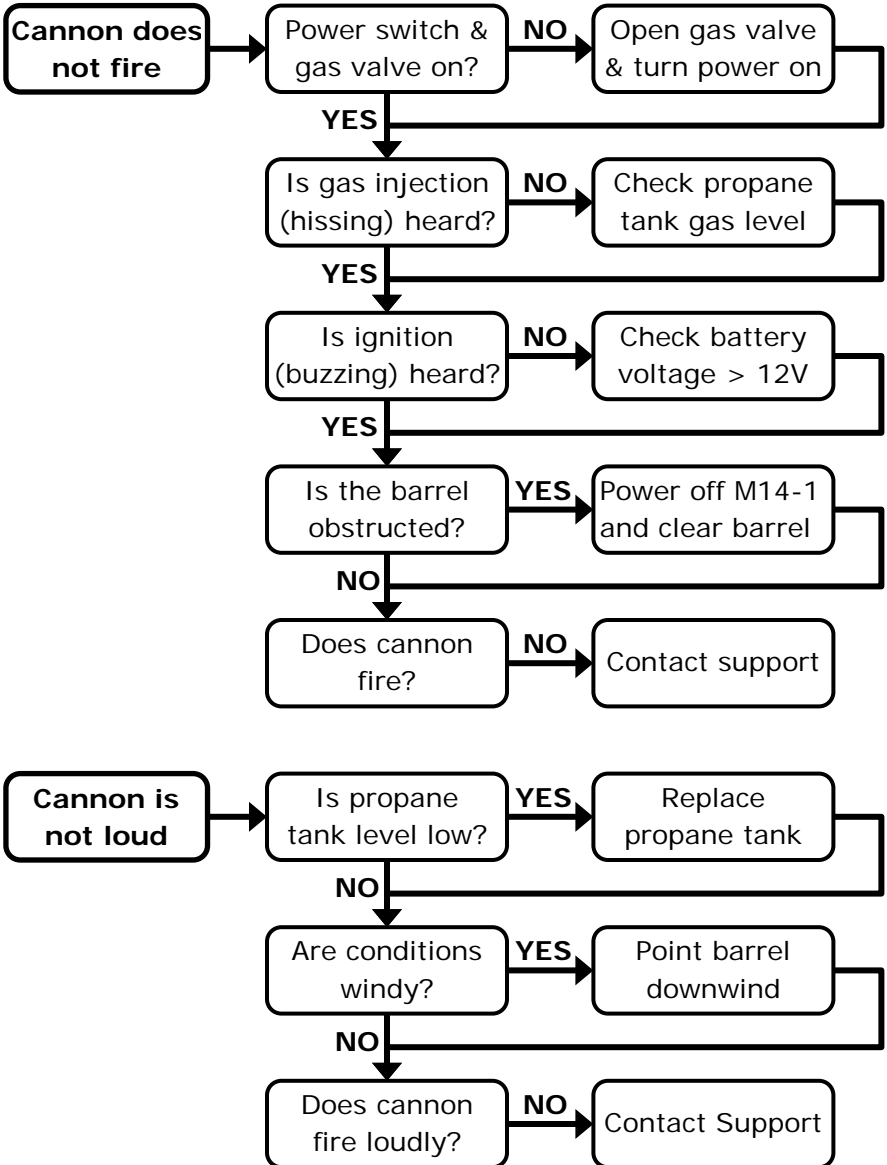

7. Legal

Applicability:

1. These Terms apply to any transaction between Sonic Sentinel, LLC (hereafter known as "Seller") and its customers (hereafter known as "Buyer" or "Buyers"). The Terms are integral to any purchase agreement, invoice, order form, or other document(s) pertaining to the sale of, or the offer to sell, Seller's products. The placement of any order for Seller's products and/or the use of Seller's products implies an agreement to these Terms in full.
2. Buyer's ability to purchase and/or use Seller's products is expressly predicated on Buyer's acceptance of these terms and conditions. Any purchase of product shall be considered a contractual agreement by Buyer to Seller's Terms as provided here: www.sonicsentinel.com/legal.

Limitation of Seller's Liability:

1. Seller shall not be liable for any general or special damages arising from the use or misuse of the Model 14-1 Sound Cannon and its accessories (hereafter known as "Product"). No warranty is provided by Seller beyond replacement due to defects in manufacturing and is limited to a refund of the purchase price. Seller's warranty is exclusive of all other warranties, and any implied warranty of merchantability and/or implied warranty of fitness for a purpose is hereby disclaimed.
2. Buyer is solely responsible for determining the suitability of Seller's products for a purpose intended by Buyer or Buyer's customers. Seller has tested products only as explained in Seller's product specifications and this manual. Buyer agrees not to use Seller's products in any way not specified by Seller's instructions and product descriptions. Buyer shall assume all responsibility for any claims, losses, damages, demands, and expenses incurred by the use or misuse of Seller's products, including the incorporation of Seller's products into other goods for sale by the Buyer.
3. Seller does not authorize or otherwise endorse Buyer to make any modification or change to Product. Any changes or modifications made by Buyer to Product, which are not expressly approved by Seller in writing, shall render any and all warranties invalid.

8. Parts View & Listing

The following M14-1 replacement individual parts and assemblies are available:

<u>Parts</u>	<u>Part #</u>
1. Injector Assembly	00006
2. Ignition Control Module	00007
3. Power Switch	00008
4. Barrel Assembly	00009
5. Coil Assembly	00010
6. Spark Plug	00011
7. Solar Controller	00012
8. Wiring Harness*	00013
9. Propane Regulator	00014
10. Lower Shroud & Cowling	00015
11. Upper Shroud	00016
12. 12VDC 8Ah Battery	00017
13. Tripod Barrel Clamp	00018
14. Propane Filter	00019

The following M14-1 accessories are available:

<u>Accessories*</u>	<u>Part #</u>
1. Tripod Extension (24in)	00020
2. Tripod Feet (Set of 3)	00021
3. Nighttime Deactivation	00022
4. Battery Charger (12VDC)	00023
5. Propane Level Sensor	00024
6. Programmable Timer	00025
7. 360° Rotating Tripod	00026

The following M14-1 activation modules are available:

<u>Activation Modules*</u>	<u>Part #</u>
1. Push-Button Remote Controls	00030–32
2. XBee Radio Modules	00033–36
3. Motion Detection Modules	00037–39

To purchase parts and accessories, and for more information, visit <http://www.sonicsentinel.com>.

* Not Pictured

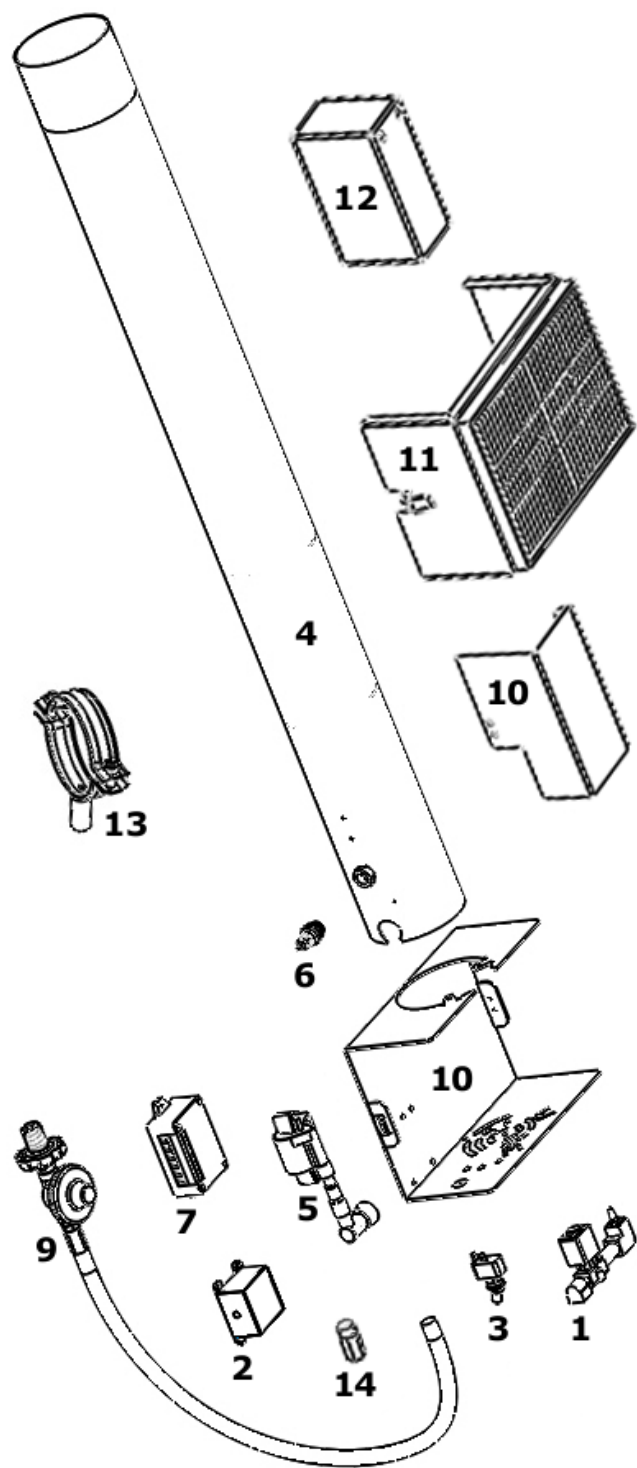

9. Warranty

Seller warrants Product against defects in materials or workmanship for a period of 1 year from the date of original sale. No warranty is provided by Seller beyond replacement due to defects in manufacturing and is limited to a refund of the purchase price. Seller's warranty is exclusive of all other warranties, and any implied warranty of merchantability and/or implied warranty of fitness for a purpose is hereby disclaimed.

10. Compliance

FCC (Federal Communications Commission): This equipment has been tested and found to comply with the limits for a Class B digital device, pursuant to part 15 of the FCC Rules. These limits are designed to provide reasonable protection against harmful interference in residential or commercial installations. This equipment generates, uses, and can radiate radio frequency energy and, may cause harmful radio interference.

IC (Industry Canada): This equipment has been tested and found to comply with the limits for a Class B digital device, pursuant to Industry Canada ICES-001, Issue 4.

EN (European Norm): This equipment has been tested and found to comply with the limits defined by EN 61000-6-3:2007 for electromagnetic emissions in light industrial applications.

